



ProteusHub™ Hardware Device
Installation Guide for Marine Electricians
Version 0.1.0

Copyright & Disclaimers

All documentation, source code, and all other content are copyright [Tocaro Blue](#) 2024. Use of these materials is subject to the terms of your Tocaro Blue ProteusCore SDK licensing agreement. Implementation in hardware is covered by several US and international pending patents. Tocaro Blue, ProteusCore, Proteus Hub, and the Tocaro Blue Stylized Trident are registered marks of Tocaro Blue LLC.

Table of Contents

Pre-Install Checklist	4
Multi-Function Display (MFD) Compatibility Check	4
RADAR Compatibility Check.....	4
Scouting Mission.....	4
Cable Routing	5
NMEA 2000 Network Check.....	5
Step by Step Installation.....	6
Choosing a Mounting Location	6
Connections	6
Initial Power-on Test.....	7
Hard Mounting.....	8
Sea Trial.....	8
Hardware Specifications	9
Appendix A: Proteus Hub Dimensions	10
Appendix B: Connection Diagram.....	14
Appendix C: Compatible Devices	15

Pre-Install Checklist

We recommend that you confirm compatibility in advance to ensure a smooth and successful installation. Compatible boats will meet the minimum requirements for mounting location, required NMEA2000 channels, and access to the onboard ethernet (MarineNet, Raynet, or similar).

Multi-Function Display (MFD) Compatibility Check

The Proteus Hub hardware device connects to the MFD with an HDMI cable, a USB cable (for touch control), and an RJ45 cable for Ethernet (to access RADAR data).

NOTE: See [LINK](#) for an up-to-date, comprehensive list of compatible MFDs

RADAR Compatibility Check

The Proteus app relies heavily on a modern marine RADAR as a perception sensor. It is important to verify your RADAR has been tested by Tocaro Blue for compatibility before installing Proteus on your boat.

NOTE: See [LINK](#) for an up-to-date, comprehensive list of compatible RADARs.

Scouting Mission

Perform a scouting inspection to find the best location to install the Proteus Hub Hardware device.

- Choose a primary MFD for Proteus
 - The MFD must already be capable of displaying your RADAR data
- Identify a mounting location for Proteus Hub
 - within 4 ft of the MFD, away from salt spray and sunlight
 - with available space for mounting (see Appendix A: Proteus Hub Dimensions)
- Ensure access to required connections:
 - Location to add a NMEA2000 Tee (included) on the NMEA2000 Bus
 - HDMI port on the MFD
 - USB/Micro USB port on the MFD
 - Accessible RJ45 port on the MFD or a nearby ethernet switch

NOTE: You may need to unplug things like analog cameras, or SD card readers from the back of the MFD you plan to plug Proteus into in order to access all of the needed cables.

NOTE: "Ethernet" is called different names by different manufacturers: Garmin – MarineNet or BlueNet, Raymarine – RayNet, and Simrad – Ethernet.

Cable Routing

- Required Cables List and links:
 - [NMEA 2000 Tee Connector](#)
 - [NMEA 2000 Backbone drop cable](#)
 - [Network to Fusion Cable Large to RJ45 6' ft \(Garmin\)](#)
 - [HDMI](#)
 - [USB2.0 to MicroUSB](#)
 - [Ethernet CAT8](#)
- Cable source
 - Depending on your application, you may prefer to use the manufacturer's recommended cables, or generic cables from online sources like Amazon
 - Alternately, you can purchase a set of Garmin cables directly from us. Garmin cable sets include waterproof boots for the MFD side
- The Proteus Hub package includes waterproof boots to seal the cables on the Proteus end

NMEA 2000 Network Check

The following PGNs are required for Proteus to have full functionality. Go to the NMEA 2000 section of your MFD's Communication Settings to verify the following PGN's are available:

- 127250 Heading
 - Required
- 128267 Water Depth
 - Required for Depth Alerts and Active Remapping functions
 - **NOTE:** Not required for surface collision awareness
- 129025 Rapid Position
 - Required
- 129026 Course/Speed Over Ground
 - Often available from the same source that provides 129025 Rapid Position
 - **NOTE:** Not required. but highly recommended
- 129038 AIS Position Report
 - Usually available from VHF radios with NMEA2000 AIS capability
 - **NOTE:** Not required but AIS related functionality will be diminished

See Appendix C: Compatible Devices for a list of recommended compatible NMEA devices.

Step by Step Installation

You have completed your scouting mission and know where you will mount the Proteus Hub device. Now it's time to do the installation. We recommend setting the device near the mounting area, making all the connections with the cables, and then running a full-power test to verify Proteus is fully operational. You should only hard-mount the device in place after verifying operation.

Choosing a Mounting Location

Before starting, we recommend shutting off power to the NMEA2000 Bus. Before drilling holes or applying any adhesive to permanently mount the Hub, place the device in the install location (or as close to it as it can get) and run all of the cables from the Proteus Hub to the MFD

- Slide waterproof boots onto cables before plugging the cables into the Hub
- About Orientation & Heat Sync
 - Ensure the Hub device can be mounted so that the “Proteus” logo is in the correct orientation and readable
 - The large metal fins on the front of the device need to be clear of direct obstructions so that they provide cooling for the Proteus Hub
 - Always mount so that the “Proteus” Logo on the front face of the Hub device is in the proper orientation.
 - **NOTE:** Do not hard mount the Proteus Hub device in place yet. Set it near the mounting location so that all of the cables can be run and the initial power on test can be performed
- Route cables from Proteus Hub to the MFD
 - This may require some finesse and is normally the most time-consuming part of the installation process
 - **NOTE:** At this stage in the installation, we recommend waiting to zip-tie or perform any thorough cable routing or cleanup
- Mounting Bracket and Hardware
 - The mounting bracket holes are 3/16th diameter.
 - Typical hardware is provided, but you may use hardware that is the appropriate length and style for your needs

Connections

Proteus Hub device requires the connections listed below. Please make connections in the order presented here to prevent power failure.

- NMEA 2000 + Power to NMEA 2000 Bus
 - Connect the NMEA Backbone cable to the Proteus hub from the NMEA Tee.
NOTE: do not connect directly to the MFD, connect to the backbone only
 - [NMEA 2000 Backbone drop cable](#)

- [NMEA 2000 Tee Connector](#)
- USB to MFD
 - [USB2.0 to MicroUSB](#)
- Ethernet to MFD or to Ethernet Switch
 - [Ethernet CAT8](#)
 - Or [Network to Fusion Cable Large to RJ45 6' ft \(Garmin\)](#)
- HDMI to MFD
 - [HDMI](#)

See Appendix B: Connection Diagram for a complete schematic.

Initial Power-on Test

Now that the appropriate cables are connected, it's time to boot up the Proteus application on the MFD. This is a minimum self-test procedure. For operating instructions please see the Proteus Quick Start Guide.

- Apply power to the Proteus unit by plugging in the NMEA2000 cable and powering up the vessel electronics
 - When the NMEA Backbone cable is powered the device should power on and the LED will blink green
- On the connected MFD, go to the "video input" page and ensure the video source is set to the correct HDMI input
- You should see either an AMI boot screen, or the Proteus loading screen. Wait for the proteus app to load, this can take one to two minutes
- The Proteus app will open to the Diagnostics page first. Information on this page will update as various systems pass or fail tests. If the tests required for minimum operation pass, the app will automatically transition to the 3D view.
 - If needed, re-access the Diagnostics page by clicking on the status lights in the top left corner of the app.
- Ensure that all PGNs have a green indicator
 - If some PGN's are showing orange or red, double check the recommended device list in the NMEA 2000 Network Check list.
- Next, close Diagnostics, and go to Menu > My Vessel
 - Fill in the vessel's dimensions on the Dimensions tab
 - Click on the Radar/GPS tab and ensure the appropriate radar model is selected on the right-hand side.
 - Go to Draft/Transducer and set the appropriate Transducer Depth
NOTE: this value is used for depth remapping and MUST be accurate)
 - On the Identification tab, fill in the information
- Click Save and Return
- If you have a WIFI network on the boat, head to Menu > User Account and enter the WIFI information
- In the same Menu > User Account page, log into your Tocaro Blue account

- Finally, hit Save and Return to get back to the 3D view. Click the Map button in the top right corner to enter the 2D view
- Ensure that the vessel's position and orientation look correct on the map
 - If the position is incorrect, you may need to select a different position source. This can be configured in Menu > My Vessel > NMEA Hardware
 - If the orientation/heading looks incorrect, you may need to calibrate the vessel's digital compass, or apply a bias in the Proteus Radar/GPS settings
- Activate the vessel's radar and ensure that radar blobs begin to appear on the map.
 - This can be done using the controls at the bottom of the Proteus main screen

Hard Mounting

After completing the Initial Power-on Test, mount the Proteus Hub Device in place using the provided mounting bracket.

- For easier access to the mounting plate, start by unplugging the cables from the Proteus Hub device. Leave the cables connected to the MFD.
 - At this stage, you may want to go ahead and route and secure the cables in a tidy fashion, but leaving slack to ensure they can connect to the Hub
- Mark the hole locations for the four holes in the mounting bracket.
 - Use the included Mounting Template for a full-size hole template
- Drill pilot holes as recommended in the Mounting Template
- Mount Proteus Hub in place & attach bracket using the included screws
- If you have not yet routed the cables in their final locations, please do so before re-attaching the cables to the Hub
 - **NOTE:** We recommend pulling cables tight, but leaving enough slack so that the cables can be separated from cable bundles if needed
- After mounting the device and routing the cables, reconnect cables and ensure that the Proteus device powers on and boots up on the MFD
 - After successfully booting up the Proteus app, finalize the installation by screwing the waterproof cable boots into the Proteus Hub device

Sea Trial

We recommend performing a Sea Trial upon completing the Proteus Hub installation. This allows you to ensure proper functionality and walk through the various features and capabilities of the Proteus product. While not a required part of the process, we find that this final test can help answer questions that the owner/captain might have about the system.

NOTE: For best operation of Proteus, a properly calibrated digital compass is required. We often find that digital compasses are either never calibrated or are calibrated poorly. During the Seat Trial, you may need to perform the proper compass calibration procedure. See the Proteus Quick Start Guide for details.

Hardware Specifications

The Proteus Hub hardware provides a powerful computer in a compact and reliable package. These specifications are provided to help understand the space and power requirements for the device.

- Marineized Rugged Enclosure
 - Hard anodized 6061-T6 aluminum with integrated heat sink
 - Delrin (Acetal homopolymer) plastic backing with Buna-n gasket
 - Delrin mounting bracket with multiple mounting options
 - Sealed and booted connectors for HDMI, USB, and Ethernet connectors
- Antennas
 - BLE (Bluetooth Low Energy)
 - Wifi
 - 4G Cellular
 - Spare (Unused)
- Connectivity
 - WIFI or 4G Cellular
 - Network connection is not required while underway.
 - The connection is used for software, firmware, and map updates
- Power
 - Via NMEA2000 bus
 - 10-16 VDC power
 - 15 Watt maximum
 - NOTE:** on vessels with a large number of devices, a power injector may be required
- Required Cables
 - HDMI to HDMI
 - USB to USB
 - NMEA 2000 drop cable
 - Ethernet

Appendix A: Proteus Hub Dimensions

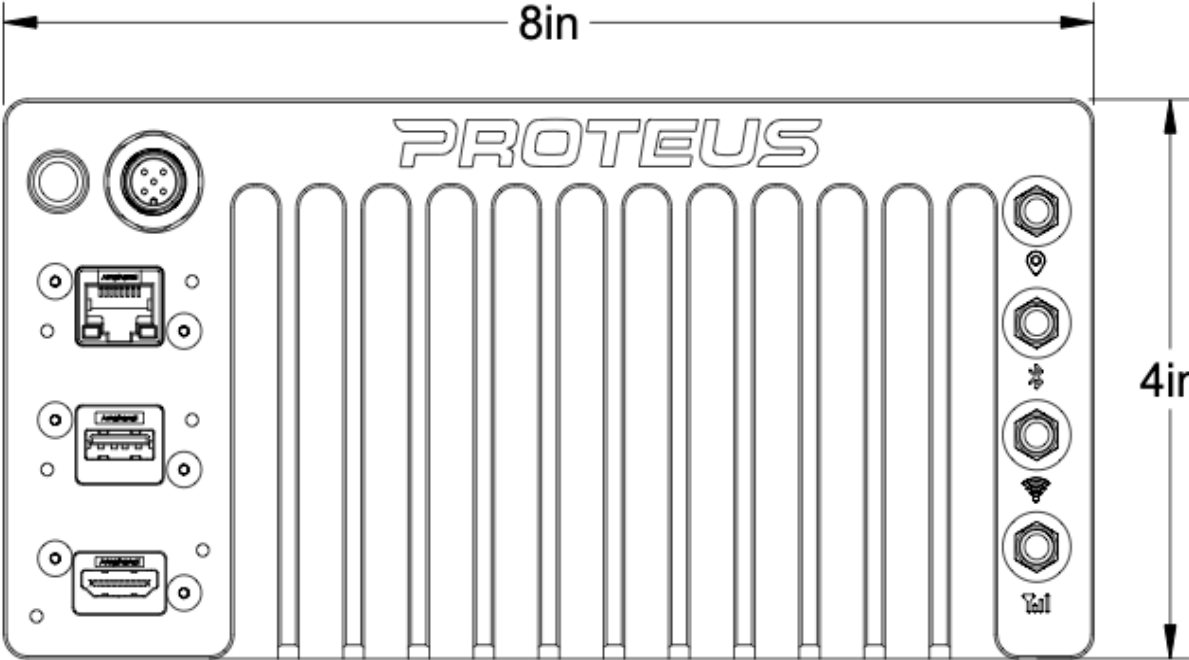

Device dimensions without mounting bracket

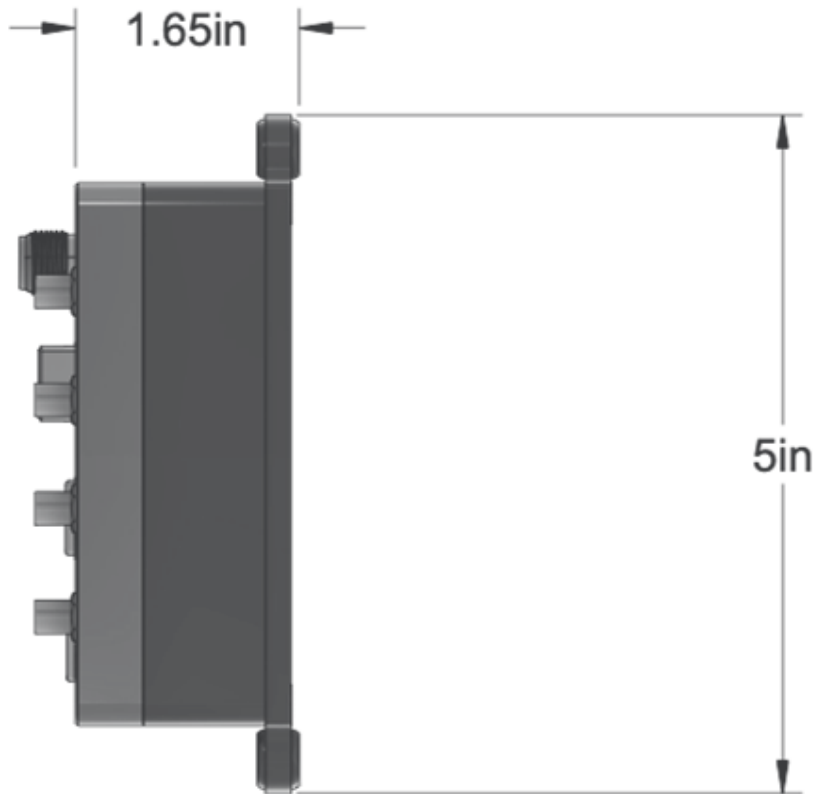
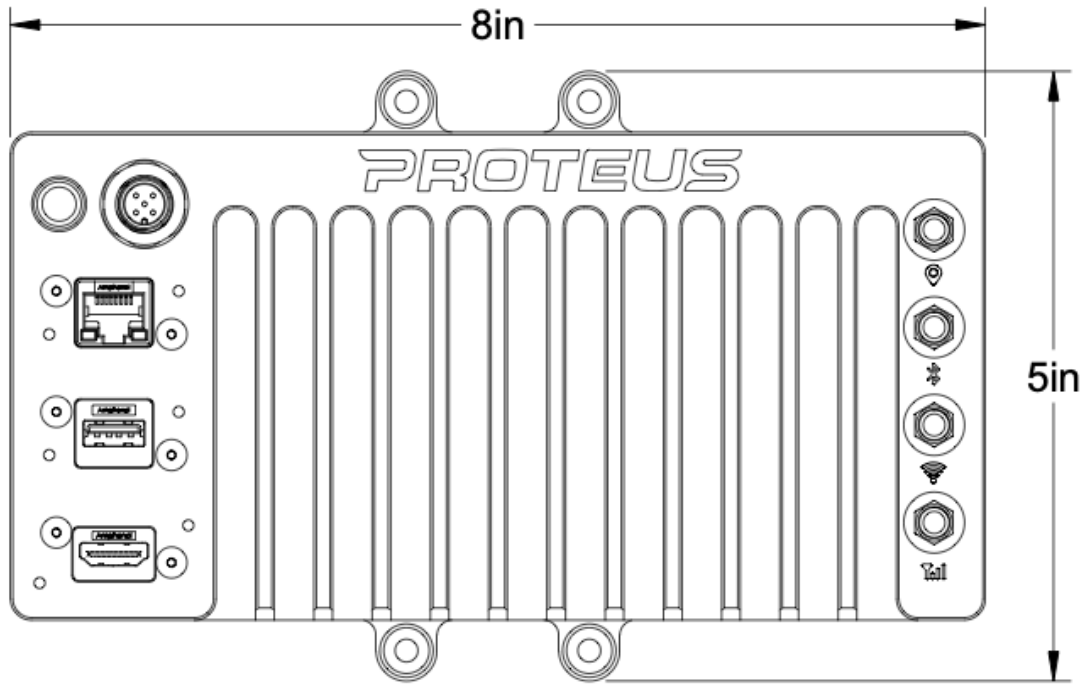

Side View dimensions with mounting bracket attached to the back

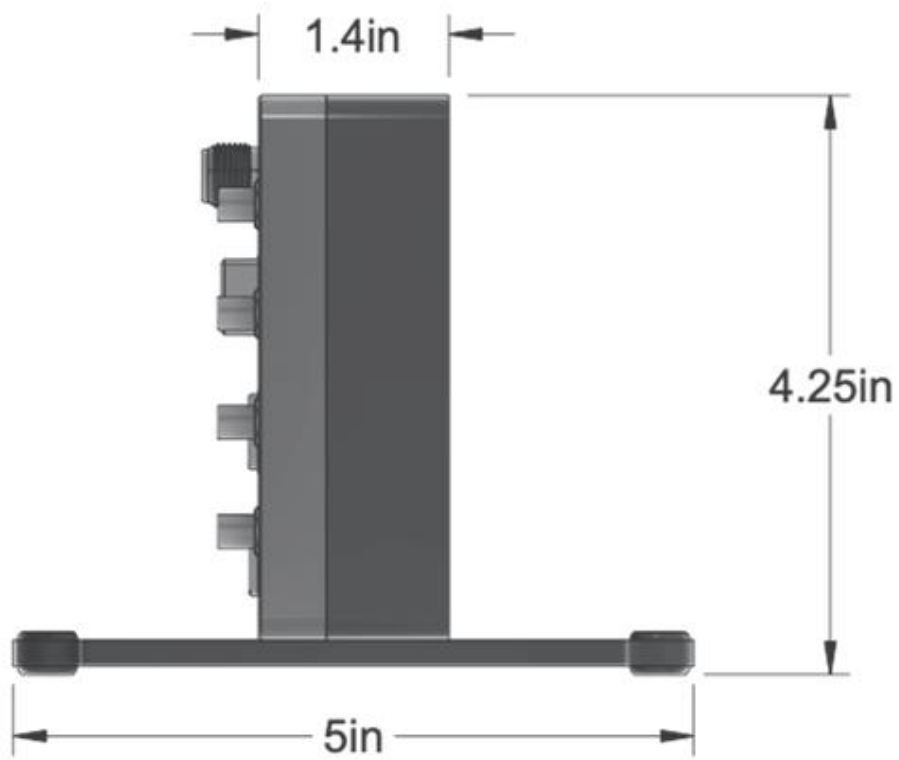
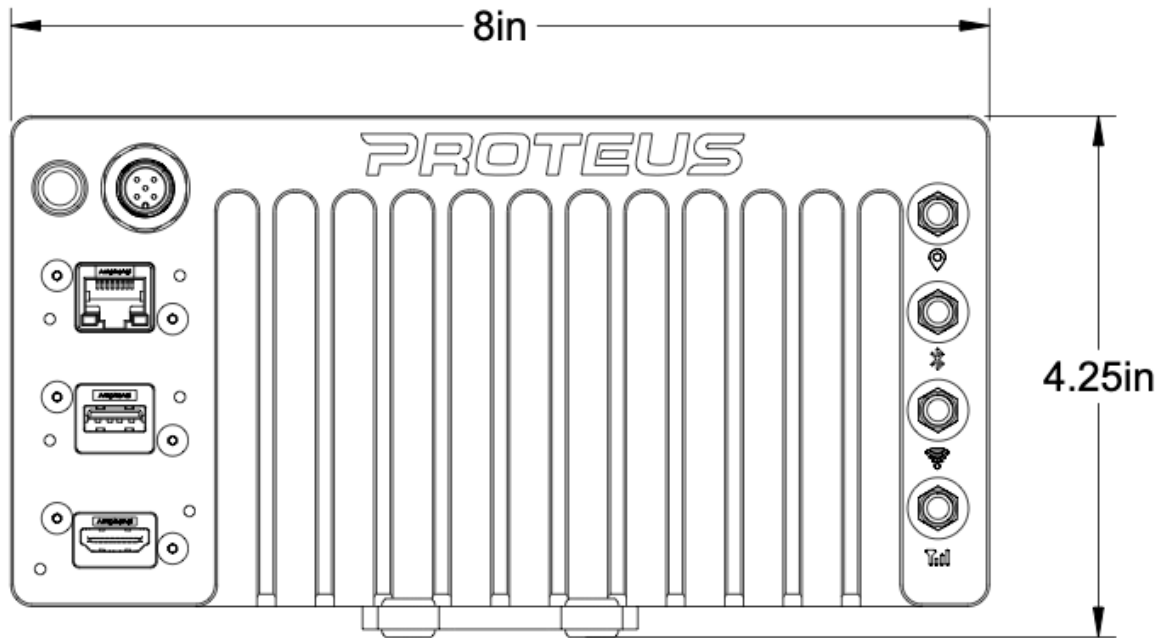

Side view dimensions with mounting bracket attached to the bottom

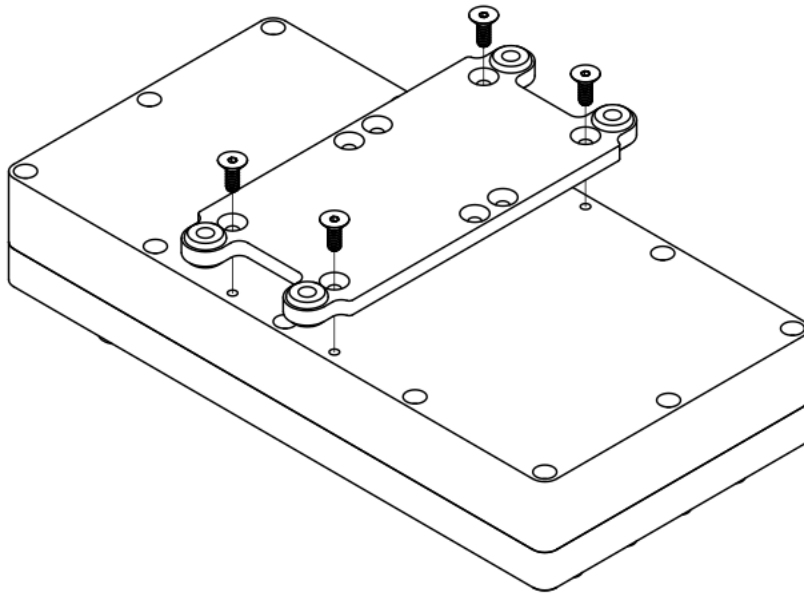

Mounting bracket pictured attached to the back of the Proteus Hub with provided Allen head hardware

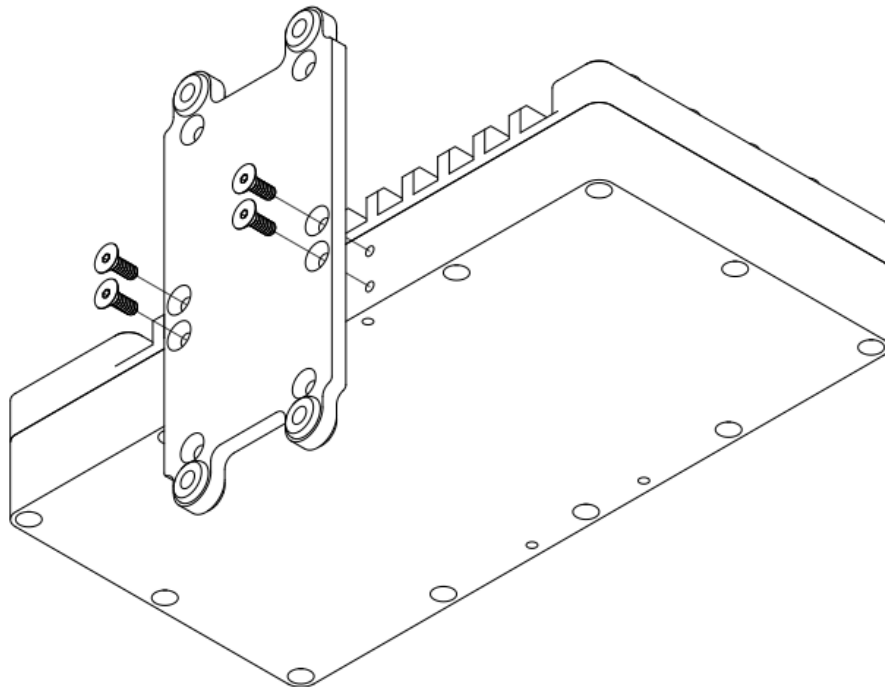

Mounting bracket pictured attached to bottom of Proteus Hub using provided Allen head hardware

Appendix B: Connection Diagram

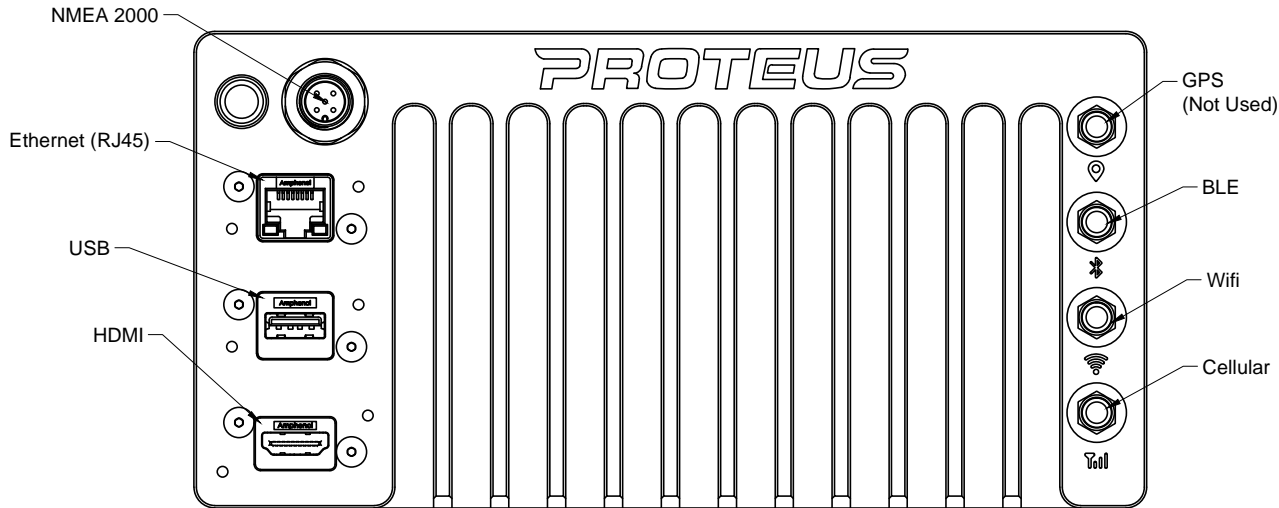

Appendix C: Compatible Devices

This list includes equipment that has been tested by Tocaro Blue for full compatibility with the Proteus application. Most devices that provide the NMEA2000 PGNs listed in NMEA 2000 Network Check are sufficient.

Heading	Water Depth	GPS/Position	AIS
Simrad Precision-9 Compass	Garmin Intelliducer NMEA 2000	Simrad HS75 GNSS Compass	B&G V60 VHF Radio
Garmin 9 axis heading sensor	AIRMAR DST 810 Smart Transducer	Simrad HS60 GPS Compass	Garmin VHF 215 AIS Marine Radio
Garmin SteadyCast Heading Sensor	Lowrance Active Imaging 3 in 1 Transducer	Simrad Precision-9 Compass	Garmin AIS 800 Blackbox Transceiver
Lowrance Point1 GS and Heading Sensor		Garmin SteadyCast Heading Sensor	
		Lowrance Point1 GS and Heading Sensor	